



Section 3

Mechanically and manually operated valves



Mechanically and manually operated valves

Function	Port size	Flow (Max)	Individual mounting		Manifold mounting		Series
			Inline		sub-base		
3/2 - 2/2	1/8" - 1/4"	0.18 C _v					1100
3/2 - 2/2	1/8" - 1/4"	0.14 C _v					
5/2 - 5/3	1/4"	1.35 C _v					1800



Mechanically and manually operated valves

Individual mounting

Inline	
--------	--

Manifold mounting

sub-base	
----------	--



Function	Port size	Flow (Max)	Individual mounting
3/2 NO-NC, 2/2 NO-NC	1/8" - 1/4"	0.18 C _v	Inline

OPERATIONAL BENEFITS

1. Short stroke with high flow.
2. Powerful return spring.





















HOW TO ORDER

Port size	Universal valve	NC only valve
		
1/8" NPTF	1111A-xxx	1161A-xxx
1/4" NPTF	1113A-xxx	1163A-xxx

MECHANICAL OPERATOR ►

xxx

Code	Description	Code	Description	Code	Description
 O11	Cam roller parallel to ports 1 & 2	 O23	Lever locking pull perpendicular to ports 1 & 2	 O31	Push button
 O12	Cam roller perpendicular to ports 1 & 2	 O24	Lever non-locking pull perpendicular to ports 1 & 2	 O32	Push button (panel mounting)
 O13	Lever cam parallel to ports 1 & 2	 O25	Lever locking push parallel to ports 1 & 2	 O33	Push button with guard
 O14	Lever cam perpendicular to ports 1 & 2	 O26	Lever non-locking push parallel to ports 1 & 2	 O36	Palm button
 O21	Lever locking push perpendicular to ports 1 & 2	 O27	Lever locking pull parallel to ports 1 & 2	 O37	Palm button (panel mounting)
 O22	Lever non-locking push perpendicular to ports 1 & 2	 O28	Lever non-locking pull parallel to ports 1 & 2	 O38	Palm button with guard

TECHNICAL DATA	
Fluid :	Compressed air, vacuum, inert gases
Pressure range :	Vacuum to 150 PSI
Lubrication :	Not required, if used select a medium aniline point lubricant (between 180°F to 210°F)
Filtration :	40 μ
Temperature range :	0°F to 120°F (-18°C to 50°C)
Flow (at 6 bar, ΔP=1bar) :	1/8" - 1/4" : (0.18 C _v)
Leak rate :	50 cm ³ /min

Spare parts : • Operator : 1100A-XXX (see codification).

Options : • BSPP threads.

DIMENSIONS

Dimensions shown are metric (mm)

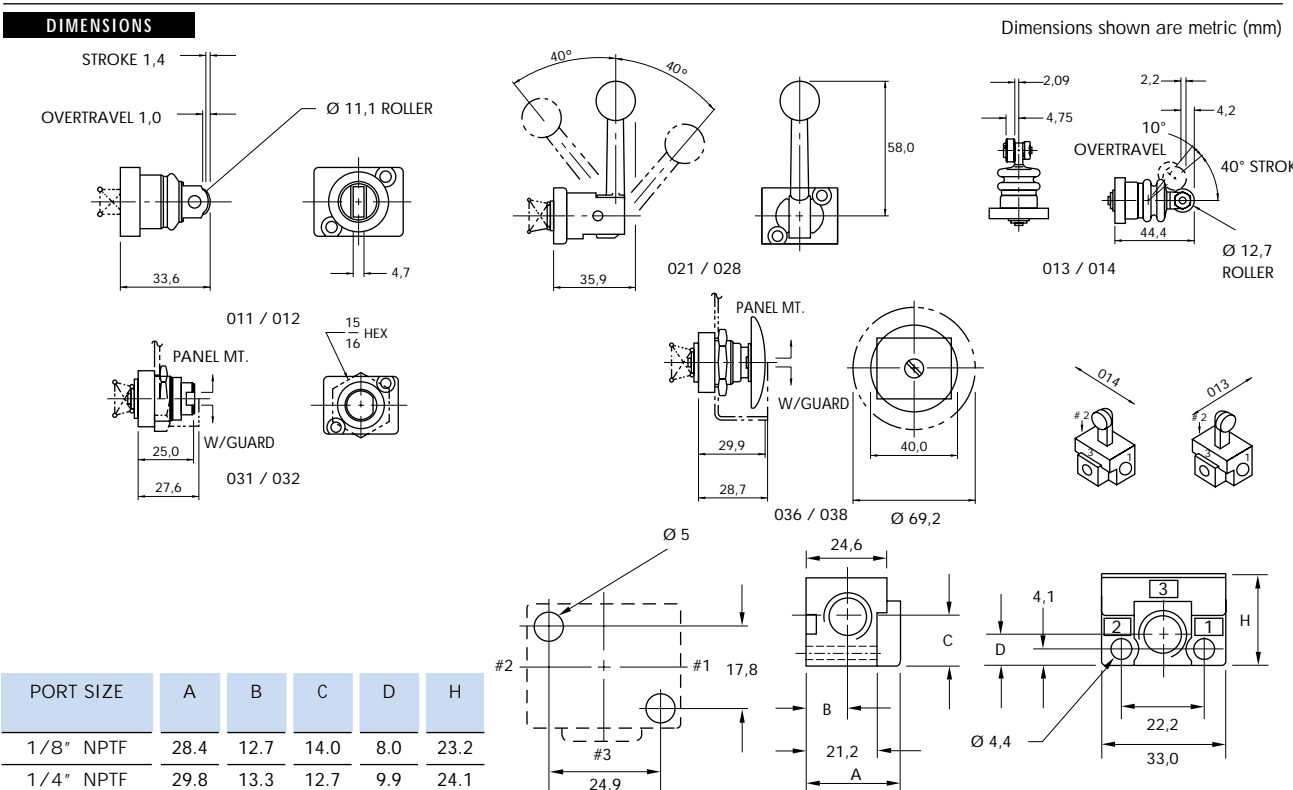

PORT SIZE	A	B	C	D	H
1/8" NPTF	28.4	12.7	14.0	8.0	23.2
1/4" NPTF	29.8	13.3	12.7	9.9	24.1



Function	Port size	Flow (Max)	Manifold mounting
3/2 NO-NC, 2/2 NO-NC	1/8"	0.14 C _v	sub-base

OPERATIONAL BENEFITS

1. Short stroke with high flow.
2. Powerful return spring.







HOW TO ORDER

Port size	Universal valve	NC only valve
		
Valve less base	1130A-xxx	1170A-xxx
Sub-base 1/8" NPTF	1132A-xxx	1172A-xxx

MECHANICAL OPERATOR ►

xxx

Code	Description	Code	Description
 025	Lever locking push parallel to ports 1 & 2	 031	Push button
 026	Lever non-locking push parallel to ports 1 & 2	 028	Lever non-locking pull parallel to ports 1 & 2
 027	Lever locking pull parallel to ports 1 & 2		

End plate kit (Port size 1/4" NPTF) : A2-5004-01.

TECHNICAL DATA	
Fluid :	Compressed air, vacuum, inert gases
Pressure range :	Vacuum to 150 PSI
Lubrication :	Not required, if used select a medium aniline point lubricant (between 180°F to 210°F)
Filtration :	40 μ
Temperature range :	0°F to 120°F (-18°C to 50°C)
Flow (at 6 bar, ΔP=1bar) :	1/8" : (0.14 C _V)
Leak rate :	50 cm ³ /min

Spare parts : • Operator : 1100A-XXX (see codification). • Function plate : A2-7009. • Pressure seal between bases : 16226.
• Tie-rod (x2) : 19546.

Options : • BSPP threads.

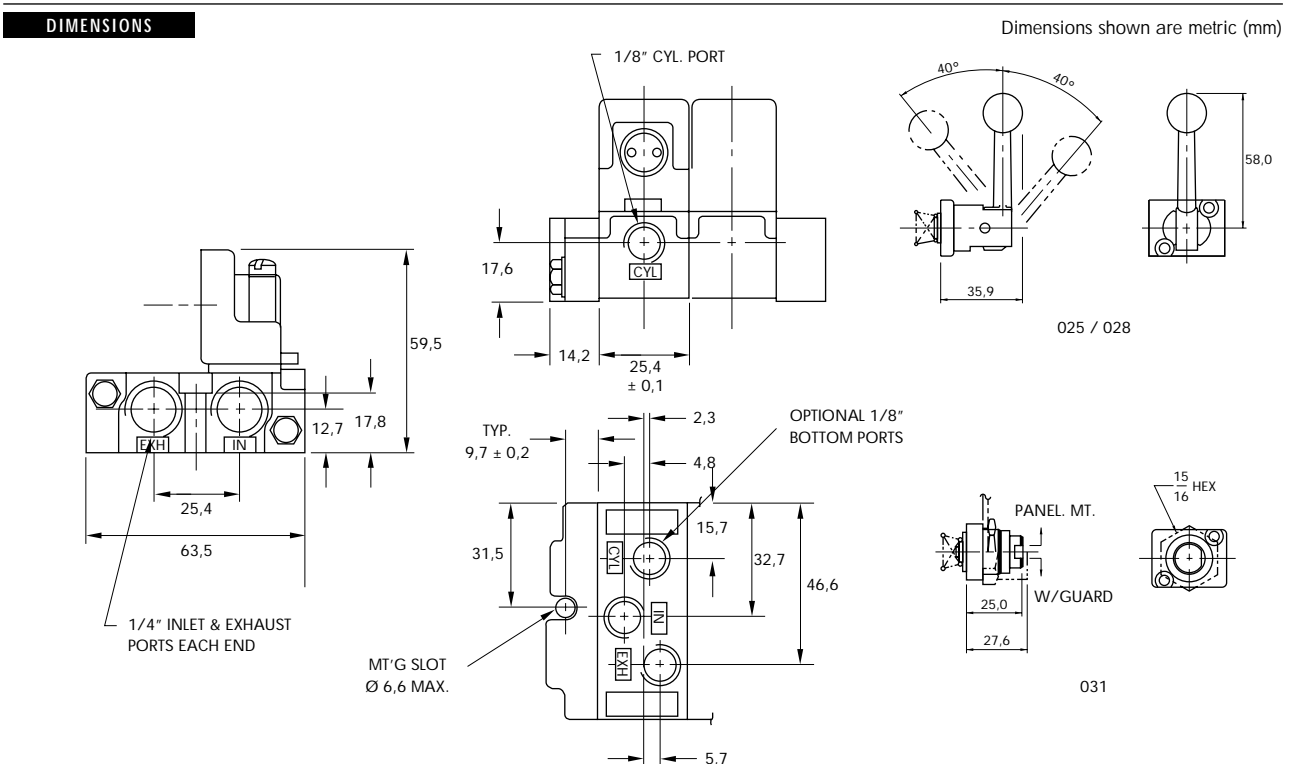



Mechanically and manually operated valves

Individual mounting

Inline

Function	Port size	Flow (Max)	Individual mounting
5/2	1/4"	1.4 C _v	Inline

OPERATIONAL BENEFITS

1. Short stroke with high flow.
2. Powerful return force.
3. Bonded spool with minimum friction, shifting in a glass-like finished bore.
4. Wiping effect eliminates sticking.
5. Long service life.

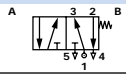
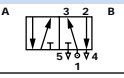

HOW TO ORDER

Port size	Single operator	Double operator
1/4" NPTF	 180001-112-xxxx	 18xxxx-112-xxxx

MECHANICAL OPERATOR ►

XXXX

Code	Description	Code	Description	Code	Description
0111	Cam roller parallel to ports 2 & 3	0024	Lever non-locking pull perpendicular to body	0033	Push button with guard
0112	Cam roller perpendicular to ports 2 & 3	0025	Lever locking push parallel to body	0034	Push Pull
0013	Lever cam perpendicular to ports 2 & 3	0026	Lever non-locking push parallel to body	0035	Push Pull (panel mounting)
0014	Lever cam parallel to ports 2 & 3	0027	Lever locking pull parallel to body	0036	Palm button
0021	Lever locking push perpendicular to body	0028	Lever non-locking pull parallel to body	0037	Palm button (panel mounting)
0022	Lever non-locking push perpendicular to body	0031	Push button	0038	Palm button with guard
0023	Lever locking pull perpendicular to body	0032	Push button (panel mounting)	0039	Push Pull palm button

OPTIONS

002X
 Replace 0 by 2 for lever operator with boot (see photo)

TECHNICAL DATA	
Fluid :	Compressed air, vacuum, inert gases
Pressure range :	Vacuum to 200 PSI
Lubrication :	Not required, if used select a medium aniline point lubricant (between 180°F to 210°F)
Filtration :	40 μ
Temperature range :	0°F to 120°F (-18°C to 50°C)
Flow (at 6 bar, ΔP=1bar) :	1/4" : (1.4 C _V)
Leak rate :	50 cm ³ /min

- Spare parts : • Operator : 18XXXX (see codification).
- Options : • BSPP threads. • 3/8" ports (ports 1,2 & 3 - MOD. 0358 required).

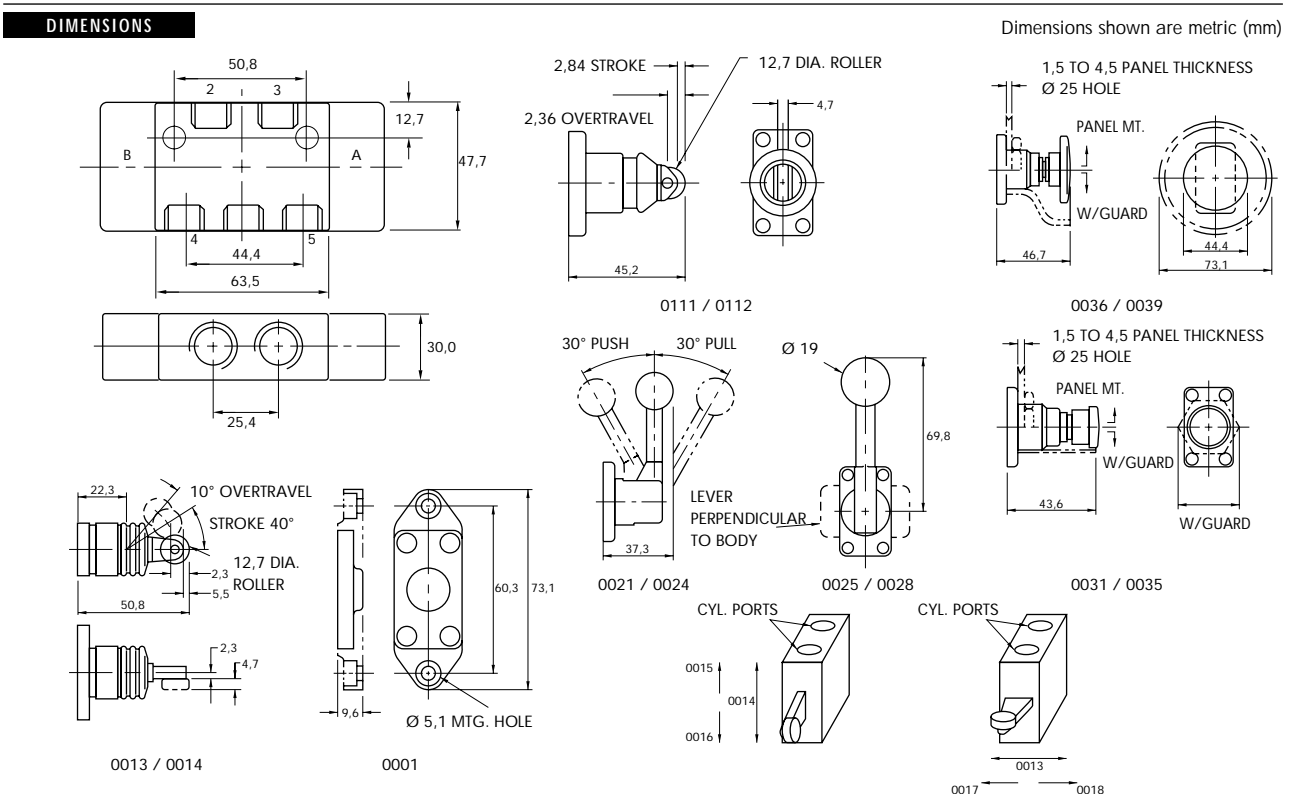







Section 4

Bases according to ISO 5599



Bases according to ISO 5599

			Series
ISO 1	ISO 2	ISO 3	
			ISO 1
			ISO 2
			ISO 3



HOW TO ORDER

INDIVIDUAL BASE

Port size	Side ports	Side & bottom ports	Bottom cylinder ports 2 and 4.	Bottom inlet port 1
1/4" NPTF	MB-A1C-221	MB-A1C-223	MB-A1C-222	MB-A1C-224
3/8" NPTF	MB-A1C-231	MB-A1C-233	MB-A1C-232	MB-A1C-234

MANIFOLD BASE

Port size	Side ports	Bottom ports	Bottom cylinder ports 2 and 4.	Bottom inlet port 1
1/4" NPTF	MM-A1C-221	MM-A1C-223	MM-A1C-222	MM-A1C-224
3/8" NPTF	MM-A1C-231	MM-A1C-233	MM-A1C-232	MM-A1C-234

Manifold fastening kit : N-63002-01.

DIMENSIONS

Dimensions shown are metric (mm)

Individual

DIN 5599/1

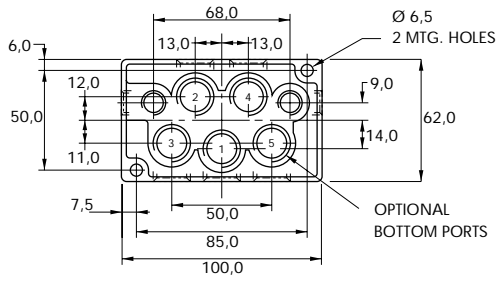
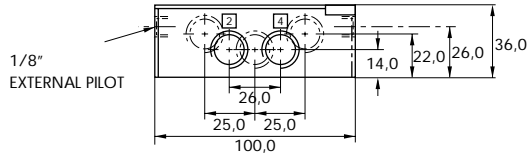

Manifold

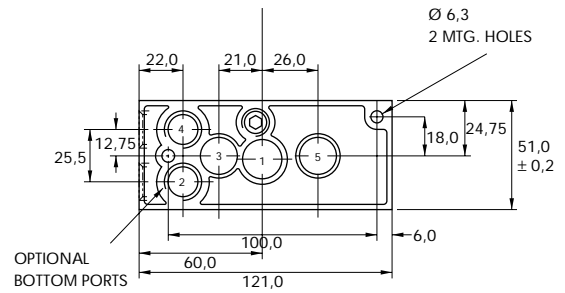
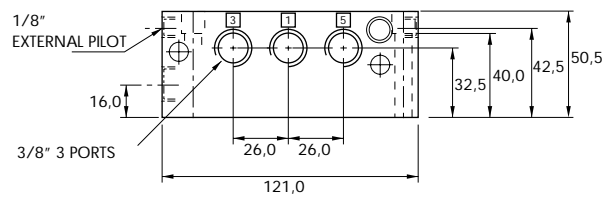



HOW TO ORDER

INDIVIDUAL BASE

Port size	Side ports	Side & bottom ports	Bottom cylinder ports 2 and 4.	Bottom inlet port 1
3/8" NPTF	MB-A2B-221	MB-A2B-223	MB-A2B-222	MB-A2B-224
1/2" NPTF	MB-A2B-231	MB-A2B-233	MB-A2B-232	MB-A2B-234

MANIFOLD BASE

Port size	Side ports	Bottom ports	Bottom cylinder ports 2 and 4.	Bottom inlet port 1
3/8" NPTF	MM-A2B-221	MM-A2B-223	MM-A2B-222	MM-A2B-224
1/2" NPTF	MM-A2B-231	MM-A2B-233	MM-A2B-232	MM-A2B-234

Manifold fastening kit : N-63002-01.

DIMENSIONS

Dimensions shown are metric (mm)

Individual

DIN 5599/1

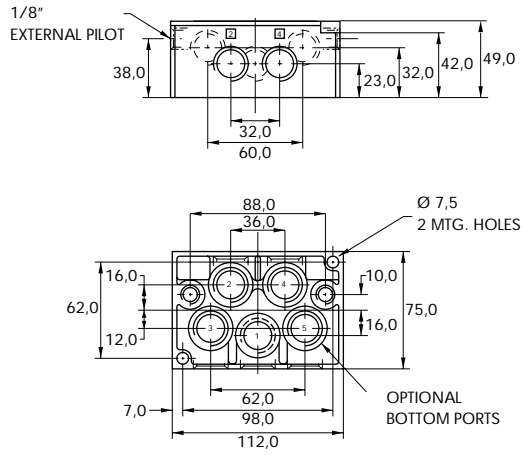

Manifold

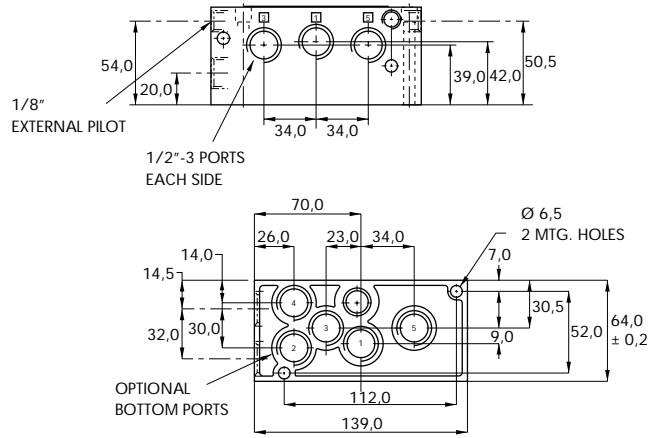



HOW TO ORDER

INDIVIDUAL BASE

Port size	Side ports	Side & bottom ports	Bottom cylinder ports 2 and 4.	Bottom inlet port 1
1/2" NPTF	MB-A3B-221	MB-A3B-223	MB-A3B-222	MB-A3B-224
3/4" NPTF	MB-A3B-231	MB-A3B-233	MB-A3B-232	MB-A3B-234

DIMENSIONS

Dimensions shown are metric (mm)

Individual

ISO DIN 5599/1

